

TOPTILE & BATHROOM

NORTH SHORE STORE //
36C HILLSIDE ROAD, GLENFIELD, AUCKLAND
T 09 444 8811

CENTRAL STORE //
58 LUNN AVE, MT. WELLINGTON, AUCKLAND
T 09 216 9533

TOPTILEANDBATHROOM.CO.NZ

FACEBOOK.COM/TOPTILEANDBATHROOM

IN WALL TOILET CISTERN FLO



Model No. Inwall Toilet TO-76B

Dimension// W365 x H400 x D540mm

S Trap 65±5mm // **P Trap** 180mm

Heavy Grade & Lift Off Soft Closing Seat

360 Degree Rinse Water Distribution for Optimal Hygiene

Easy to Clean & Radial Cleaning w/ Every Flush

WELS Rating 4 Star

Rimless Washdown Dual Flush System (4.5L/3L)

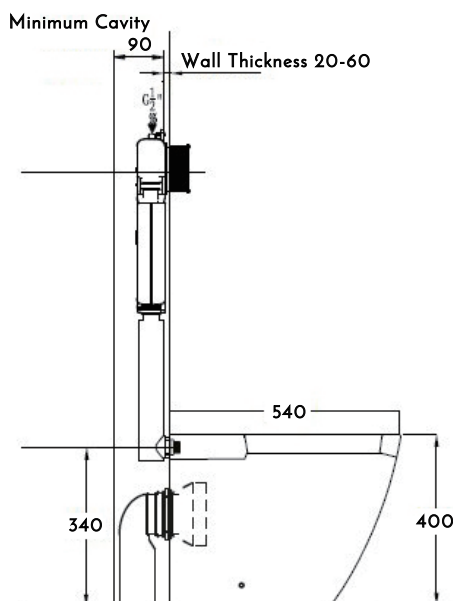

SPECIFICATION

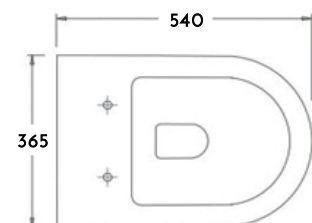
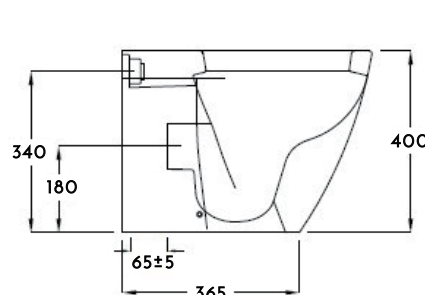

N.B. Drawings indicate the technical measurements only and is not a reflection of how the unit will look

TOPTILE & BATHROOM

NORTH SHORE STORE //
36C HILLSIDE ROAD, GLENFIELD, AUCKLAND
T 09 444 8811

CENTRAL STORE //
58 LUNN AVE, MT. WELLINGTON, AUCKLAND
T 09 216 9533

TOPTILEANDBATHROOM.CO.NZ

FACEBOOK.COM/TOPTILEANDBATHROOM

Tropea3 CISTERN

CODE	WATER USAGE	WELS RATING
Art. VS0859005	6/3 litre flush	3 Star
Art. VS0859006	4.5/3 litre flush	4 Star

This dual flush front push mechanical cistern fits inside a 90mm deep timber framed wall, and is designed to be used with wall hung pans or independent supply floor pans.

With wall hung pans use the Art. 400 pan bracket. The minimum installation height to the top of the cistern is 1070mm. Allow a further 30mm for water connection.

When using standard PVC waste pipes through the floor, a larger 150mm wall cavity may be required to accommodate them.

The push panel is easily removed, providing full access into the cistern for servicing.

Supplied with: Cistern fixings, isolator tap, 1/2" water connection, flush pipe & Kee seal.

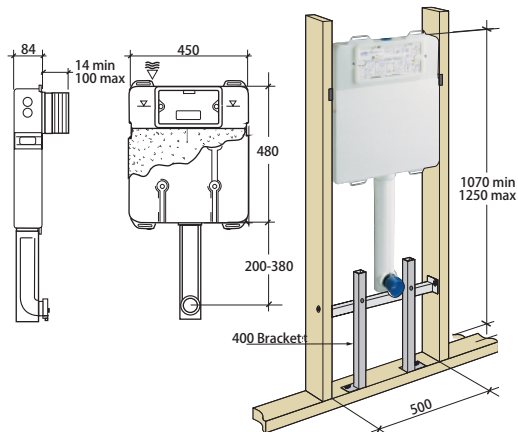

Max working pressure for all cisterns is 5 bar (500Kpa). Test pressure is 20 bar (2000Kpa). Please check wall hung pan set out for correct installation height. Max Weight 250kg.

Tropea3 90MM FULL FRAME CISTERN

CODE	WATER USAGE	WELSRATING
Art. VS0859201	6/3 litre flush	3 Star
Art. VS0859202	4.5/3 litre flush	4 Star

This dual flush front push mechanical cistern is pre-mounted inside a height adjustable, full steel frame designed to hang wall hung pans from (therefore no extra pan bracket is required).

The minimum installation height to the top of the frame is 1140mm.







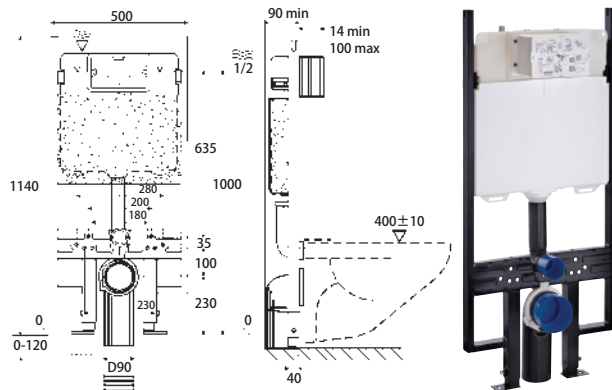

The advantages of the fully framed option is all the pipe work is pre-assembled, making for quick and simple installations, (Only 4 coach screws and connect the waste and inlet pipe).

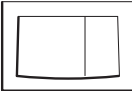
Included is a special outlet pipe and seal which enable the waste pipe to turn down through the floor inside 90mm, meaning the complete installation, including waste pipe, fits inside a standard 90mm wall cavity and teh plugs into 100mm PVC pipe.

Supplied with: Frame fixings, isolator tap, 1/2" water connection, flush pipe & Kee Seal, pan fixing kit incl. cover caps, S & P Pan Connector set to fit inside 90mm.



Max working pressure for all cisterns is 5 bar (500Kpa). Test pressure is 20 bar (2000Kpa). Please check wall hung pan set out for correct installation height. Max Weight 250kg.

TROPEA3 PUSHPLATE	WHITE	CHROME	SATIN	BRUSHED
ABS 245x165mm	 VS0872512	 VS0872534	 VS0872536	N/A
ABS 215x145mm	 VS0871301	 VS0871335	 VS0871337	N/A
METAL 245x165mm	N/A	 VS0870834	 VS0870836	 VS0872742

Evolut CABINET CISTERN

CODE	WATER USAGE	WELS RATING
Art. VS0864001	6/3 litre flush	3 Star

The Evolut cistern is available unframed, designed to be used with wall hung pans or independent supply floor pans. With wall hung pans use the Art. 400 pan bracket. The Evolut can be installed as low as 820mm, making it suitable for installation inside vanities or under low windows. However the Evolut cistern requires a minimum wall cavity depth of 150mm. The push panel can be installed either on the vanity top or the vanity front and are easily removed, providing full access into the cistern for servicing. Supplied with: Cistern fixings, isolator tap, 1/2" water connections, flush pipe and Kee seal. The Evolut may also be flushed using remote pneumatic buttons, however access is still required into the cistern for servicing.

Evolut FULL FRAME CABINET CISTERN

CODE	WATER USAGE	WELSRATING
Art. VS0864502	6/3 litre flush	3 Star

This dual flush pneumatic cistern is pre-mounted inside a height adjustable, full steel frame, designed to hang wall hung pans from. (therefore no extra pan bracket is required). The Evolut can be installed as low as 820mm, making it suitable for installation inside vanities or under low windows. However the Evolut cistern requires a minimum wall cavity depth of 150mm. The push panel can be installed either on the vanity top or the vanity front and are easily removed, providing full access into the cistern for servicing. Supplied with: Frame fixings, isolator tap, 1/2" water connection, flush pipe & Kee seal, pan fixing kit incl. cover caps, S & P Pan connector set.

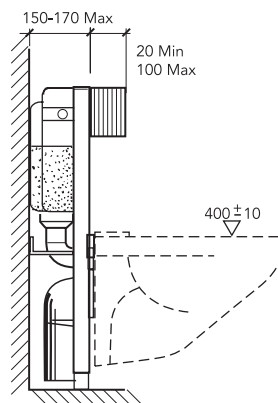
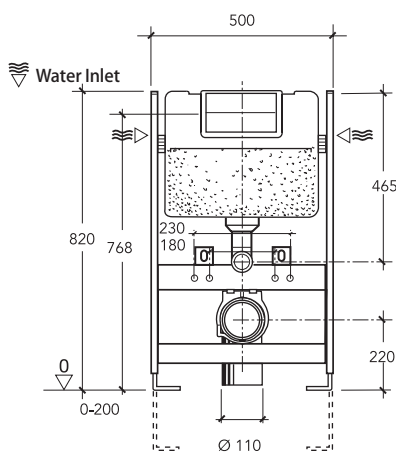

Front Push Panel

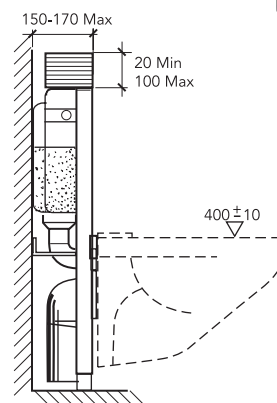

Top Push Panel

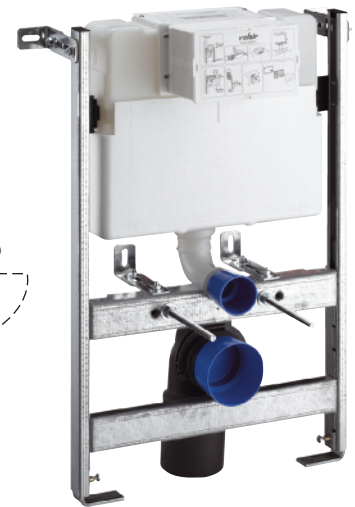

Max working pressure for all cisterns is 5 bar (500Kpa). Test pressure is 20 bar (2000Kpa). Please check wall hung pan set out for correct installation height. Max Weight 400kg.

ABS 215x145mm			VS 0872601	VS 0872635	VS 0872637
STAINLESS STEEL 215x145mm			SQUARE BUTTONS	VS 0877935	VS 0877937
			ROUND BUTTONS	VS 0877931	VS 0877933
GLASS RED 215x145mm			SQUARE BUTTONS	VS 0877305	VS 0877307
			ROUND BUTTONS	VS 0877301	VS 0877303
GLASS BLACK 215x145mm			SQUARE BUTTONS	VS 0877355	VS 0877357
			ROUND BUTTONS	VS 0877351	VS 0877353
STAINLESS STEEL 170x110mm			SQUARE BUTTONS	VS 0877965	VS 0877967
			ROUND BUTTONS	VS 0877961	VS 0877963
ABS 46mm diameter			ROUND BUTTONS	VS 0873335	VS 0873337
ABS 120x54mm			SQUARE BUTTONS	VS 0873435	VS 0873437