

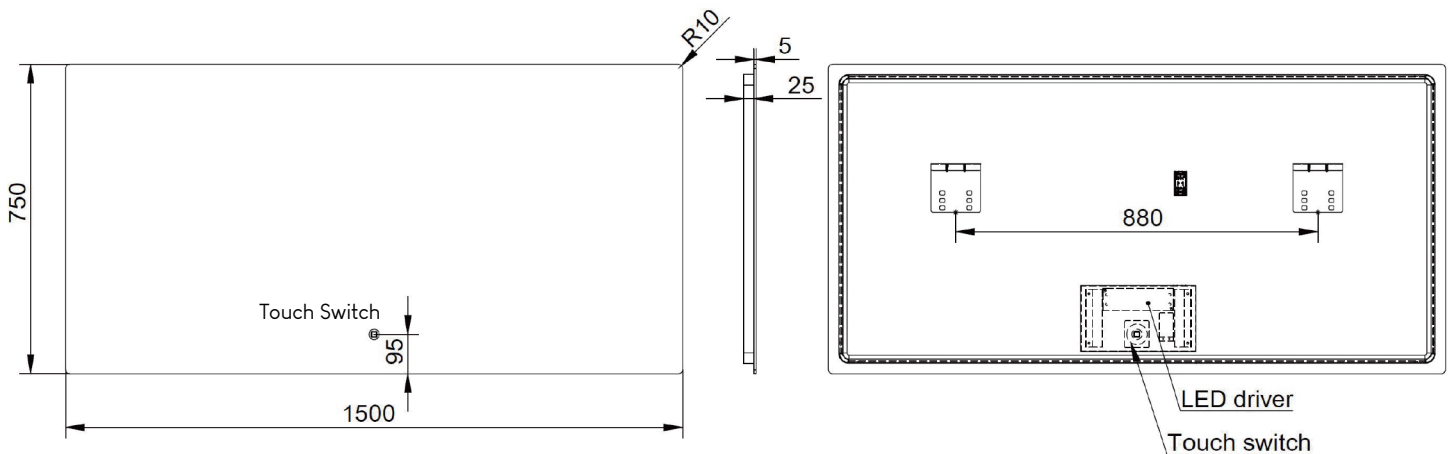







SPECIFICATION SHEET

Rectangle Backlit LED Illuminated & Demister Mirror 1500
SKU: MI-NFSL1500

Material	Frameless Copper-free Mirror and Safety Vinyl Backing
Installation	Hardwired Hang with Supplied Mounting Brackets
IP Rating	IP44
Width	1500mm
Depth	30mm
Height	750mm
Size Options	W750 900 1200 1500 1800mm



-  Touch Switch
-  Built-in Demister
-  Safety Vinyl Backing
-  Copper-free Mirror

-  SAA Approved
-  IP44
-  2 Year Warranty

