

F MAINTENANCE

CAUTION: Always turn water OFF before removing existing or disassembling the faucet. Open faucet handles to relieve water pressure and insure that complete water shut-off has been accomplished.

To keep the surface clean and bright, please clean the faucet regularly, please abide by the following procedures:

1. Use rinsing water and soft cloth, clean bilge and bilge membrane on the surface to the best of the abilities.
2. Cleaned the residua with the following cleansers only.
 - Soft liquid cleanser.
 - Colorless glass cleanser, totally soluble powder cleanser without abrasive capability.(Mixed by instructions.)
 - No abrasive cleansers waxes.
 - Never use cleanser, emery cloth or handkerchief which can rub.
 - Never use cleaners containing abrasive cleansers, ammonia, bleach, acids, waxes, alcohol, solvents or other products not recommended for chrome.
3. After cleaning, use rinsing water to clean all cleanser immediately and drying with a soft cotton cloth.
4. Carefully dismantle the aerator regularly, rinse under clean running water until any loose debris is cleared to avoid the influence to water outflow.

G SPECIAL STATEMENT

The products installation instruction is written in accordance with the latest product information, following the sustainable development strategy of the Company, to improve continually the produce's specification, performance etc., subject to change without notice. (The Company reserves the right to interpret)

BRAVAT

BY DIETSCHKE 1873

PRODUCTS INSTALLATION INSTRUCTIONS

MODEL: EL-4000T

P8191238**.*

Description: Built-in Basin Mixer Trim Set

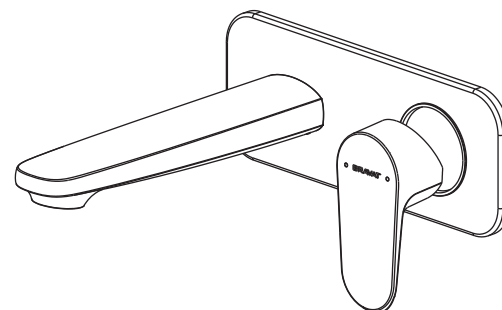
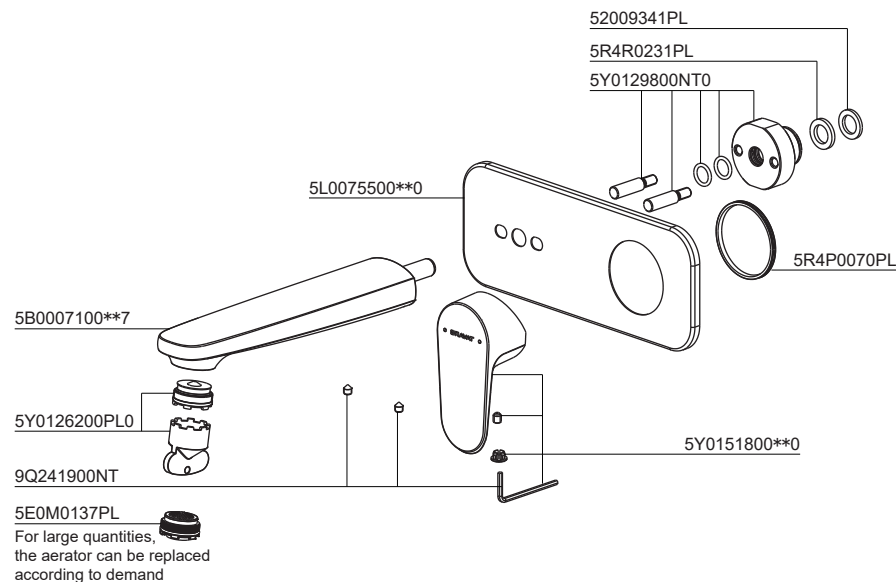

**Color Code must be specified when ordering

AP	Brushed Nickel
BW	Spraying Black
CP	Polished Nickel & Chrome
KVF	Gold
NP	Shining White
BAF	Romen Golden

A INSTALLATION DIMENSION

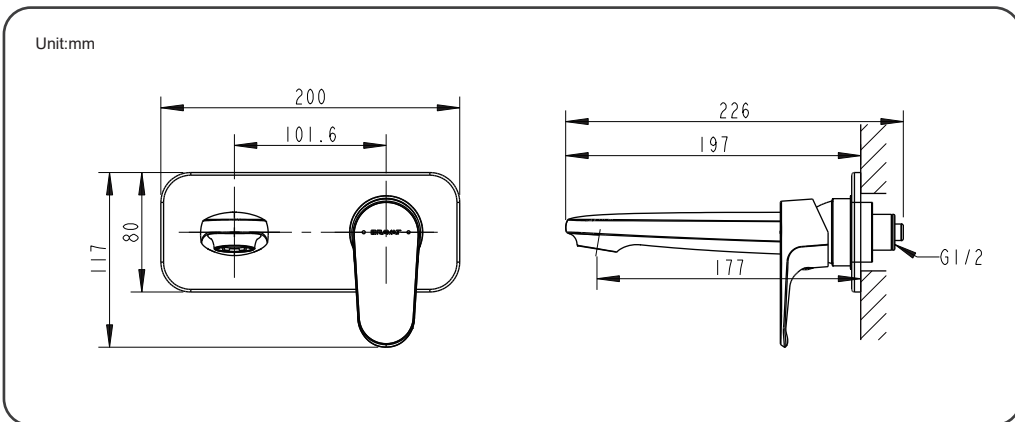

B HELPFUL TOOLS



⚠ Points for attention before installation

- Before installing the new mixer, it is essential that you thoroughly flush through the supply pipes in order to remove any remaining swarf, solder or other impurities. Failure to carry out this simple procedure could cause problems or damage to the workings of the mixer.
- Work water pressure: 0.15 - 1.0 MPa (including cold and hot).
- If the pictures and statements in the 'Installation Specifications' is unconfirmed with practicality, please take practicality as standard.

C INSTALLATION STEP

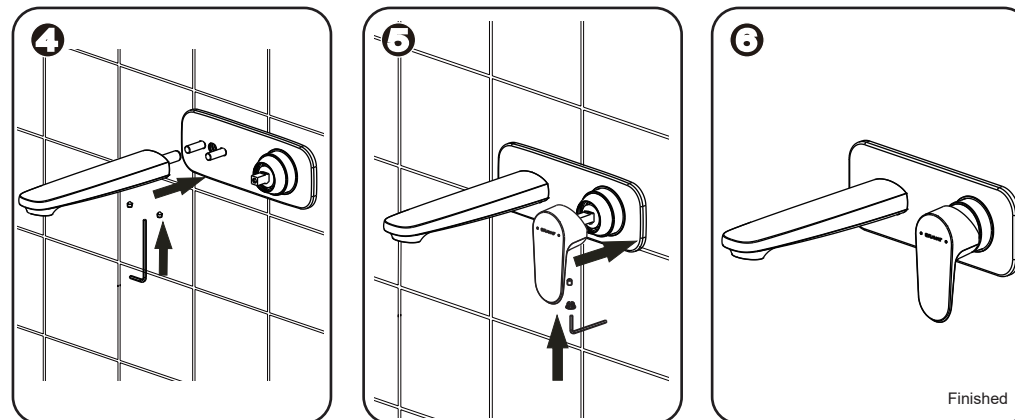
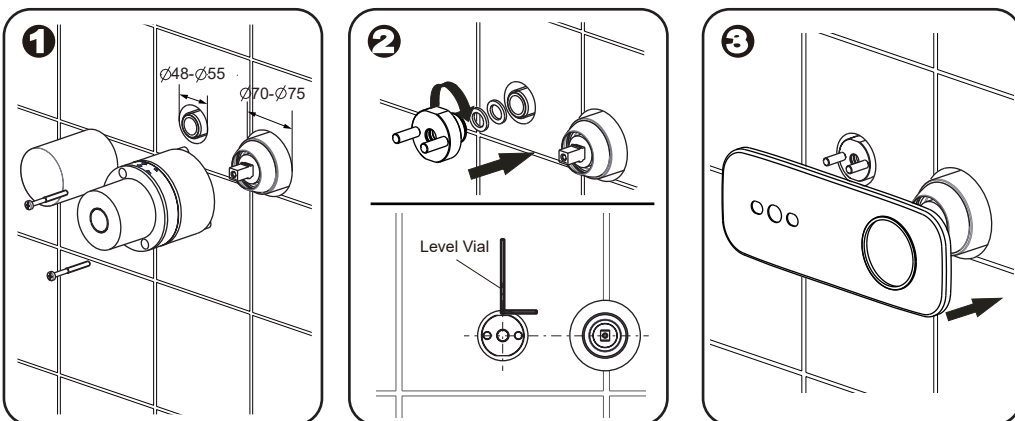

D FAUCET OPERATION

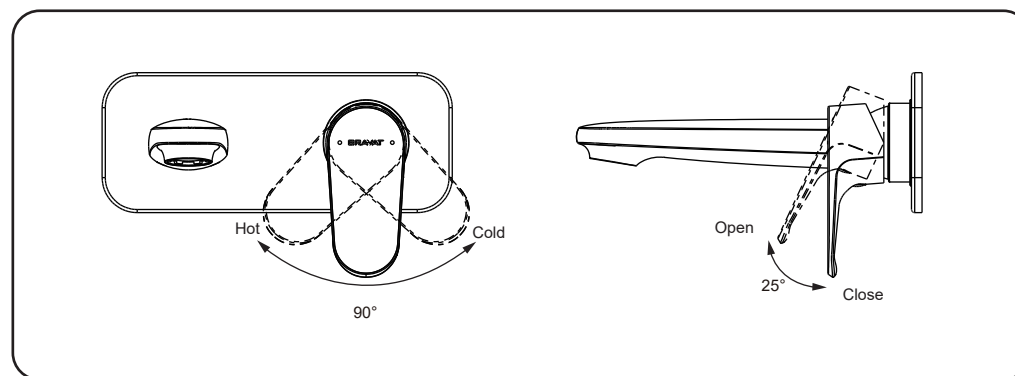

E SPECIFICATION

GB This technical product information is exclusively for the installer or trained specialists. Please pass these instructions on to the user.

Application:
Operation with unpressurized storage heaters is not possible. Use for indoor public places and common residence.

Specifications:
Hot and cold water inlet pressures should be equal.
Static inlet pressure range: 0.15 - 1.0 MPa
New regulation: 0.5 MPa maximum static pressure at any outlet within a building.
(Installation shall be in accordance with the AS/NZS3500 series of Standards.)

Hot water inlet temperature: max. 80°C
Recommended (energy saving): 60°C
Environment temperature: 5°C ~ 45°C

If static pressure exceeds 5 bar, a pressure-reducing valve must be fitted.

Avoid major pressure differences between hot and cold water supply.

Installation:
Flush piping system prior and after installation of fitting thoroughly (Consider EN 806)!
Fitting a temperature limiter is possible.

Function:
Check connections for leaks and check function of fitting.

Maintenance:
Inspect and clean all components and replace if necessary.
Shut off water supply for maintenance work.

When installing the cartridge, ensure that the seals are correctly seated.
Tighten the screws evenly and alternately.

Replacement parts: see exploded drawing.
Care: see Care Instructions.