

ARUVO®

OASIS | NESSO Smart Toilet Instruction Manual

Apply to STO-G7/STO-G9

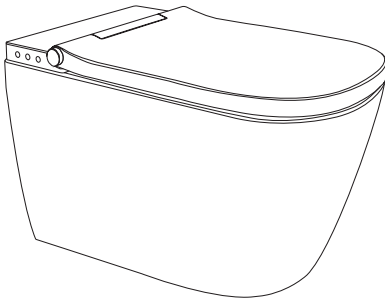
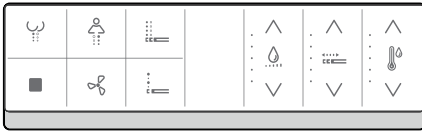

STO-G7

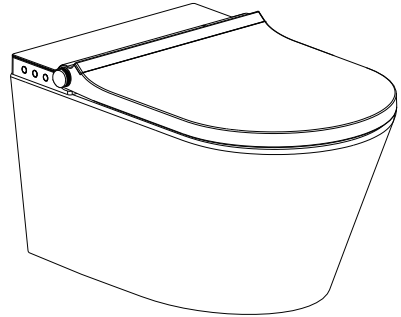

STO-G9

OASIS and NESSO — Innovating Smart Hygiene Solutions

Thank you for purchasing your OASIS and NESSO Smart Toilet. To ensure safe and optimal operation, please read this manual carefully before use. After installation, provide both the Installation Manual and Instruction Manual to the end user. Retain this document for future reference.

Important Notes

- Illustrations in this manual are for reference only. Slight design variations may exist in the actual product.
- Installation must comply with:
 - The National Construction Code Volume Three (Plumbing Code of Australia).
 - Applicable local regulatory requirements.
 - Standards AS/NZS 3500 and AS/NZS 2845.2 (as current at time of installation).

Installation Guidelines

1. Pressure Requirements:
 - Maximum working pressure: 500 kPa. If exceeded, a pressure-limiting valve must be installed.
 - Securely fasten the toilet pan to the floor using the supplied mounting kit.
2. **Backflow Prevention:**
 - This unit includes an integrated **Type B Break Tank (>25mm Air Gap with overflow)**, compliant with AS/NZS 2845.2 and the Plumbing Code of Australia (PCA).
 - The bidet seat meets WMTS-051 standards and incorporates a Type B Break Tank.
 - A licensed installer must evaluate whether an additional Reduced Pressure Zone (RPZ) valve is required.
3. Connection & Testing:
 - Tighten all inlet connections to a maximum torque of 10N·m.
 - Conduct a leakage test before initial use.

Usage & Maintenance

- Suitability: Designed for domestic and commercial environments. Constructed with moisture-resistant, cleanable materials.
- Cleaning: Use mild soapy water or approved non-abrasive cleaners. Avoid harsh chemicals or abrasive tools.

Compliance & Safety

- Installation and maintenance must be performed by a qualified plumber.
- Failure to adhere to guidelines may void warranties or compromise safety.

For further assistance, contact our customer service team or consult a licensed plumbing professional.

Contents

Chapter 1 Safety caution	02
1.1 Symbol and Meaning	03
1.2 Normal using	03
1.3 User requirements	03
1.4 Use only when the device is in a normal state	03
1.5 Toilet body using	03
1.6 Battery using	04
1.7 Other safety precautions	05
Chapter 2 Overall product overview	11
2.1 Toilet body	11
2.2 Remote control front button illustration	12
2.3 Remote control back button illustration	13
2.4 Key panel description	13
2.5 Function display list on the back of the remote control	14
Chapter 3 Operating Instruction	15
3.1 Initialization Instructions	15
3.2 Toilet Button Description	17
3.3 Rotate Knob operation instructions	18
3.4 Remote button operation instructions	19
3.5 Descaling reminder setting (the remote's back)	27
Chapter 4 Cleaning and Maintenance	28
4.1 Toilet seat unit cleaning	28
4.2 Nozzle cleaning	28
4.3 Pre-wet on and off	29
4.4 Remote control cleaning	29
4.5 Deodorizing device cleaning	29
4.6 Descaling	32
4.7 Waste disposal	33
4.8 Product maintenance	33
4.9 Winter product aintenance	34
Chapter 5 Fault predication and Troubleshooting	35
Chapter 6 Technical data	39

Chapter 1 Safety caution

In order to prevent harm and property damage to users or others, please read [safety caution] carefully and be sure to comply with it !

1.1 Symbol and Meaning



Warning

If this sign is ignored, it may cause serious injury or death.



Notice

If this sign is ignored, it may cause personal injury or property damage.

The symbol and its meaning are as follows:



The contents of this sign are: Mandatory content that must be executed



The contents of this sign are: Prohibited content



The content of this sign is: Disassembly or unauthorized modification of this product is prohibited



The content of this sign is: Connect the ground wire.



The content represented by this flag is:
Prohibition of immersion in water.



The content represented by this flag is:
Do not touch with wet hands.



The content represented by this flag is:
Prohibiting high temperature and flammable objects.

To ensure that you can enjoy the intelligent toilet seat, please read the instructions carefully, especially the safety instructions. Please keep this instruction manual properly. If the product needs to be transferred to others, please be sure to attach this instruction manual. All instructions have been confirmed in accordance with the latest technical status of the equipment at the time of printing delivery. We reserves the right to make changes as a result of further development.

1.2 Normal Using

This machine is an intelligent toilet seat with rear wash and Front wash function, can be used as a regular toilet seat. It can only be used for enclosed Spaces. Any other using will be deemed to be inconsistent with normal use. For abnormal using, we does not assume any responsibility.

1.3 User requirements

For children aged under 3 years and people who do not understand the equipment, and people with physical, sensory, mental and other defects, can use the product after safety guidance or under the supervision of other personnel.

Make sure children do not play with this product.

1.4 Use only when the device is in a normal state



Make sure the power cord is not damaged.

The power cord cannot be jammed or squeezed.

Keep the power cord away from hot surfaces and sharp edges.

Do not use the toilet seat when it is not working properly. Disconnect the power supply, close the stop valve, stop the water supply, contact the customer service hotline to avoid product failure and damage caused by improper use.

1.5 Toilet body using

The cold water of the toilet seat shall be connected from the main water supply pipe.

Use the new hose assembly that comes with the appliance. The old hose assembly cannot be reused.

The product itself does not have the function of leakage protection, should be installed in the line of leakage protector can be used.

The fixed wiring must be provided with a device for full-stage disconnection under the condition of overvoltage class III according to the wiring rules and the contact distance.

The specification of the fixed wiring power line is the nominal cross-sectional area of the conductor 1-2m² (17-14AWG)

For additional protection, the installation of a residual current device (RCD) having a rated residual operating current not exceeding 30 mA is advisable in the electrical circuit supplying .

Ask your installer for advice.

Confirm that the grounding end of the power supply wire is 10mm (3/8 ") longer than the live wire (L) and zero wire (N).

please make sure that the electrical junction box has been fixed on the wall before install the product.

Condensation moisture may occur if the temperature of toilet is moved from a colder to a hotter location. Please turn off the device for a few hours.

Do not contaminate, spray or clog the cleaning sprayer on purpose.

Please do not flush newspaper, diapers, sanitary napkins and other articles into the toilet seat , they are easy to block the product. Maintenance work must be carried out by the relevant professional staff.

Please do not use the unrecommendation accessories

1.6 Battery using



Do not touch skin, eyes or mucous membranes if battery acid leaks.

If you touch the acid, flush the affected area with plenty of water and see a doctor immediately.

Keep the battery out of reach of children .If swallowed, batteries can be life-threatening .If the battery has been swallowed, seek medical advice immediately.

Do not charge the battery, do not use other tools to reactivate the battery, do not remove the battery, put it in the fire or make it short circuit.

When the battery runs out, remove it from the control immediately. Otherwise the liquid may leak and cause damage.

Do not put the old and new batteries into the remote control.

Clean the battery and contacts before loading the battery. Pay attention to the correct polarity of the battery when installing.

If the control is not used for a long time, please remove the battery.

Do not put the battery in extreme conditions: do not contact with heat or exposure to the sun. Otherwise, leakage may occur.

Do not short the positive and negative terminals of the remote control.

1.7 Other safety precautions



People with disabilities and lack of experience or common sense (including children) should use the product under the supervision of a designated person.

This product must connect the cold water supply (water temperature about 4 ~ 30 ° C), otherwise it may burn or machine fault.

In case of abnormality or failure, please immediately disconnect the power supply, close the inlet Angle valve and stop using.

The abnormal and fault conditions are as follows :

- The product is cracked or damaged
- Products smoking
- Abnormal sound and burnt smell
- Product heating anomaly
- Water seepage from inside pipes and products

Continued use regardless of product failure may result in electric shock, fire, injury, or indoor seepage.



Do not put your fingers or other objects into or block the drying outlet. Otherwise, it may cause scald, electric shock or parts damage.

This product belongs to electrical products, so please do not install it in places where it is easy to be soaked by water or high humidity.

Do not spill water or detergent on the product, the bottom of the product and the power plug, or it will cause electric shock, short circuit and fire.



Notice

Do not hold the lid or ring to pick up the product.

Do not open the lid or ring when there is something on the lid or ring. Otherwise may cause the product damage and causes the personal injury.



When using in the bathroom, make sure the power outlet is waterproof. If not waterproof measures, may cause electric shock or fire.

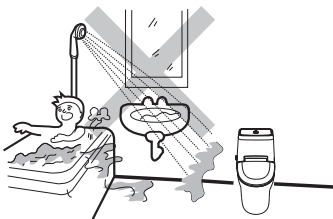

Prohibition of immersion in water

Please use a splash box, Do not spray water or detergent on the body and power plug. May cause product damage or fire, electric shock.



Connected the ground wire

Check the power socket is grounded or not. This product must be ground good. Can only be connected to the dedicated 220v-240v, 50|60Hz, 10A with ground fault circuit breaker or ground leakage protector circuit.

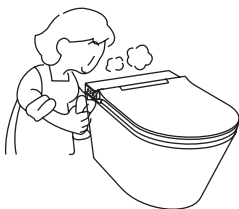

Mandatory compliance

After removing the dust from the plug, be sure to firmly insert the power plug into the socket. Unplug and clean with a dry cloth.



Turn off the power

Please cut off the power and pull out the plug before removing or cleaning the product. It may cause electric shock or fire.

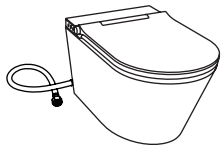

Prohibited

Do not bend or twist the water supply hose.
It may cause water leakage.



Prohibited

Do not use the following items to clean the product: Gasoline, banana water, benzene, paint thinner, decontamination powder and nylon brush.

May damage the inlet pipe or product.

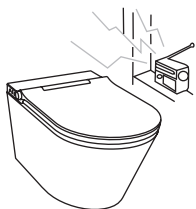

Prohibited

Keep away from the product when using the radio.



Must be obeyed

Unplug when thundering.
May cause electric shock.

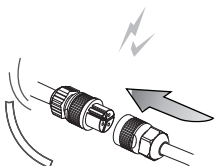

Prohibited

Do not use loose or faulty outlets.
It may cause electric shock or fire.

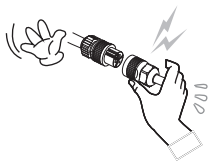

Ban on wet hands

Do not plug or unplug the power plug with wet hands.

It may cause an electric shock.



Prohibited

Do not use AC power supply that is not 220V~240V.

May cause product failure.

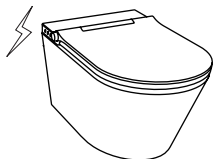

Must be obeyed

If the power cord is damaged, it needs to be replaced. To avoid danger, please observe the following: Please contact the retail store where you purchased this product or the nearby customer service center. Must be replaced by the manufacturer, its service department or an authorized professional.



Prohibited

Please do not force the cover and seat to close.
May damage the product.



Prohibited

Do not lean on the cover.
It may damage the seat cover and cause personal injury.



Turn off the power

When not in use for a long time, drain the water from the water hose and unplug the power cord.

Doing so may cause water pollution and skin infections.



Prohibited

Do not allow children to play on the seat or on the cover, do not step on, sit or place heavy objects on the cover.

May cause personal injury or damage to the product.



Prohibited

Do not install toilet in a room where frost may develop. Indoor temperature shall not be less than 4 °C.

In order to prevent product freezing, damage to the movement of the device.

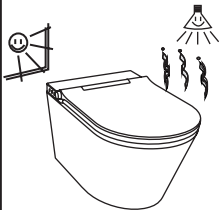

Prohibited

Do not expose the product to strong light or sunlight.

May cause fading and unstable race temperature.

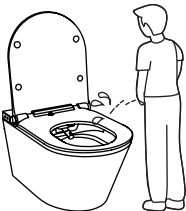

Prohibited

Do not pour urine on the body and nozzle.

Otherwise, it will lead to malfunction or stains such as pink and brown.



Prohibit high temperature

Do not place high temperature and flammable materials near the product. it may cause fire
Glowing cigarettes and other burning materials must not be thrown into the toilet.



No dismantling

For any purpose, do not separate, repair or alter this product on your own.
It may cause fire, short circuit and electric shock.

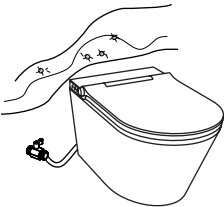

Prohibited

Do not connect any wastewater, mixed water, industrial water, seawater or other untreated or semi-treated water.
It may cause skin infection or malfunction.

Chapter 2 Overall product overview

2.1 Toilet body

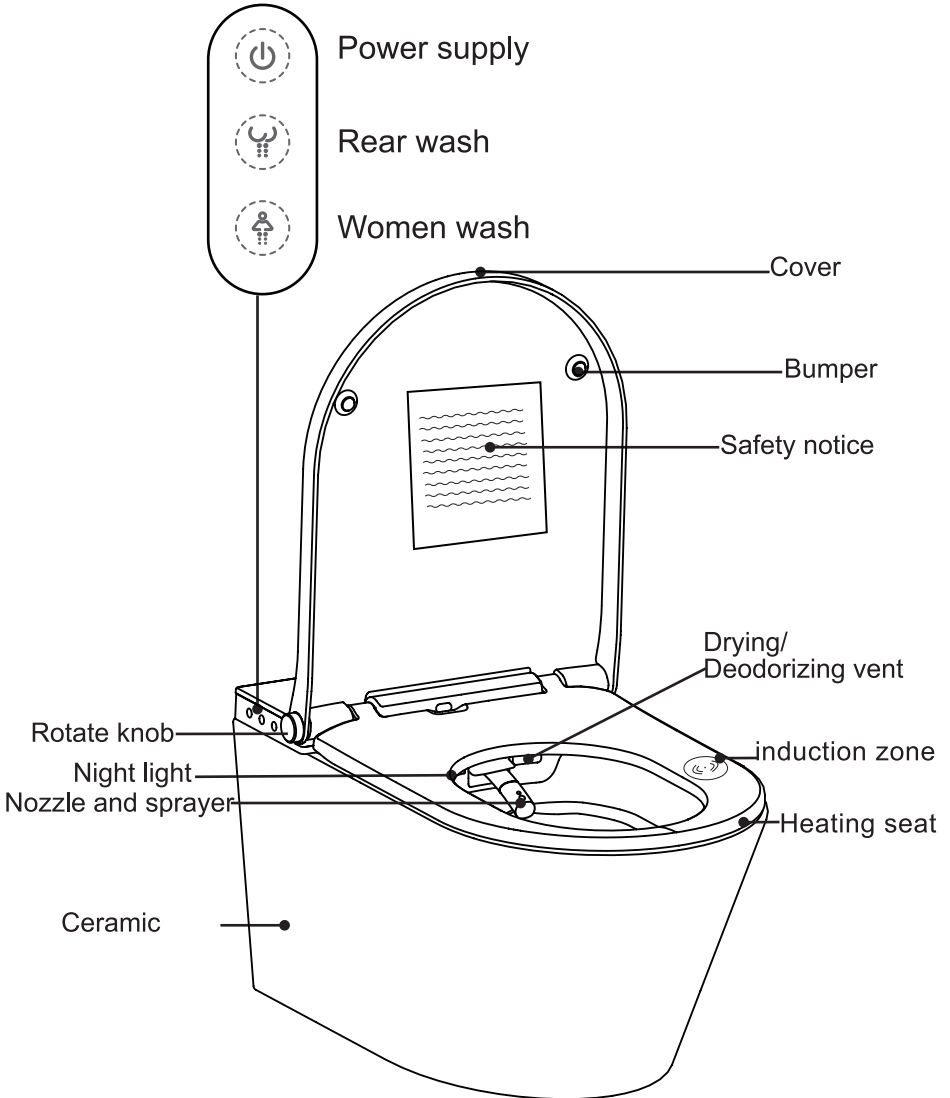

2.2 Remote control front icon illustration

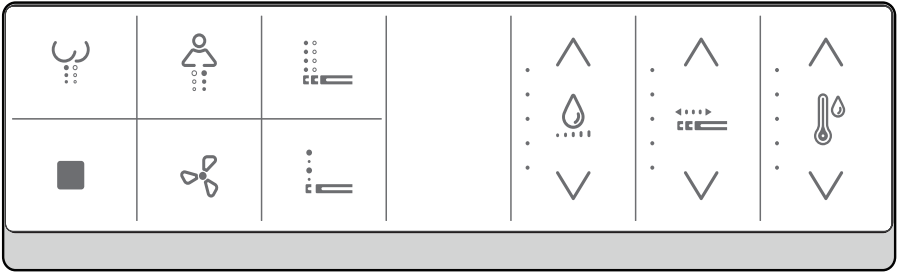

Icon	Illustration	Icon	Illustration
	「 Rear wash 」		「 Water flow adjustment 」
	「 Women wash 」		
	「 Stop 」		「 Water temperature adjustment 」
	「 Drying 」		
	「 Mobile massage wash 」		
	「 Pulse massage wash 」		

2.3 Remote control back icon illustration

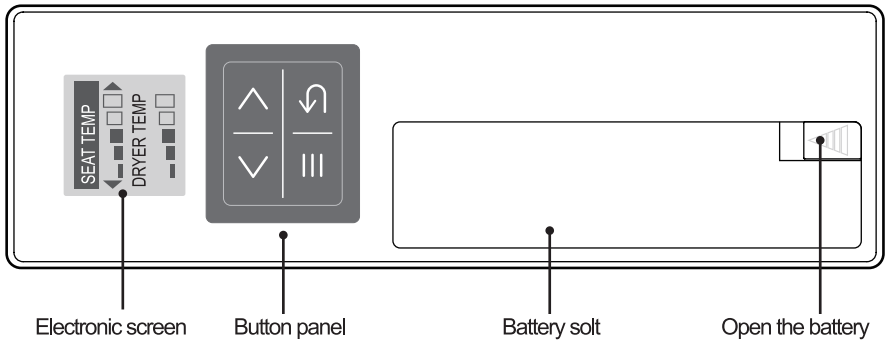

2.4 Key panel description



[ENTER]



[SET, RETURN]
 ·Return to the previous menu when setting



[CHOOSE FUNCTION]



[SELECTION SETTING]

(See pages 27-35 for details of each button function)

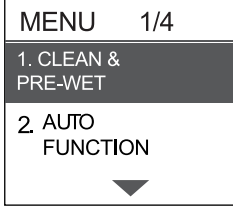

1. Press 

- Automatically switch display electronic screen



2. Looking at the electronic screen for setting

 (Up and down) Press to select function

When not selected	When selected
	 

After pressing“  ,the setting will be applied

2.5 Function display list on the back of the remote control

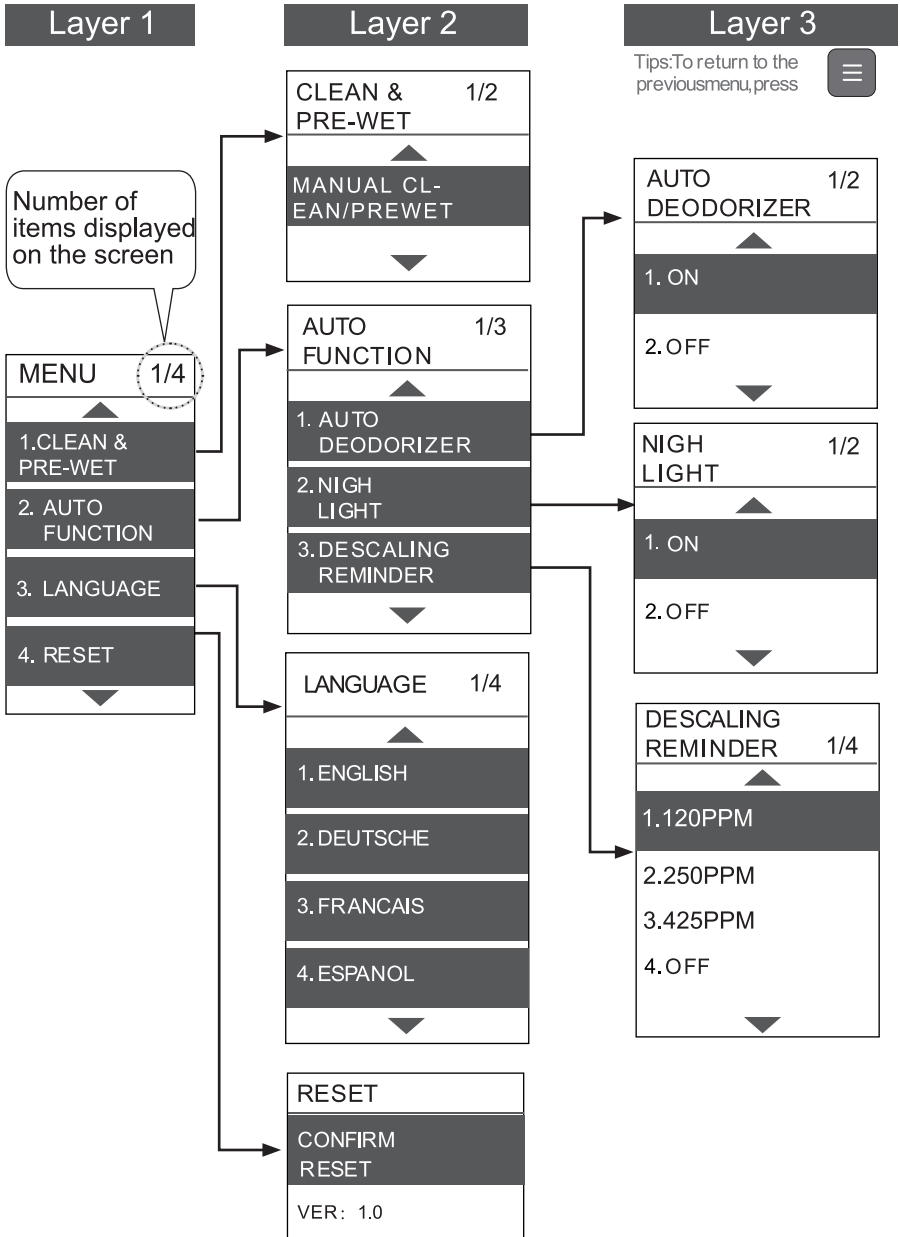

Chapter 3 Operating instruction

3.1 Initialization operation

1. Open the intake valve and make sure the tap water is connected.

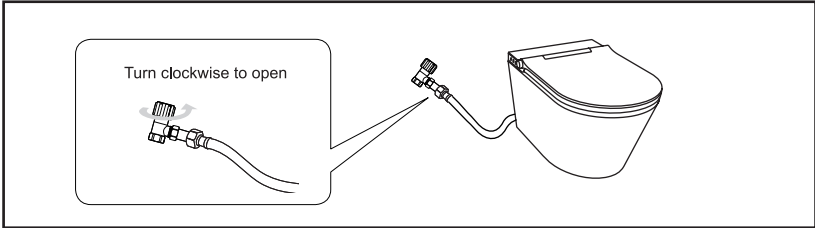

2. Battery the remote control

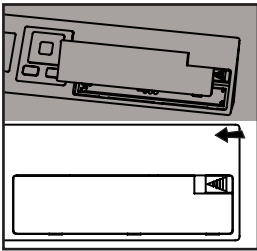

a. In the position shown on the back of the remote control, push hard to the left, and open the battery cover as shown above.

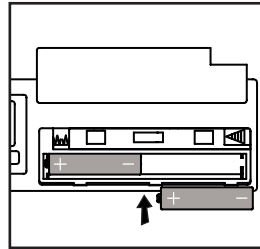

b. Install two AAA batteries. (exclude)

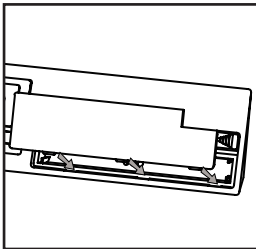

c. As shown, use the battery cover to align the notch with a small bump and cover the battery cover.

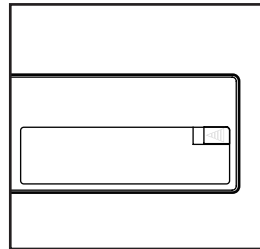

d. Complete the installation.

Try to operate the remote control. If the state light of the remote control lights up with the button, the battery will be installed successfully. If the

remote control is not available, please check whether the battery is charged and correctly installed. If the battery is run out of electricity, you can reinstall the new battery in the above way.

3.Match code

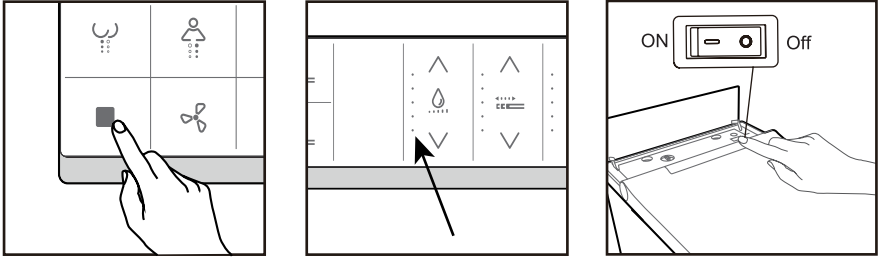

Turn off the power switch located under the top cover, insert the batteries into the remote control, then press the "STOP" button for long on the remote control, until the status light on the remote control starts flashing. Turn on the power switch located under the top cover, if the status light turn off, then it means the code matching is successful.

If the code matching is unsuccessful, the status light will automatically turn off after 30 seconds, then try again as described above please. If still unsuccessful, please consult the professional staff.

4.Press the switch button

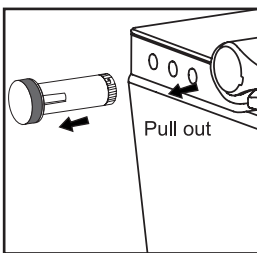

a.Pull the rotate knob control re-mote out horizontally (note that the knob snaps toward the top cover of the toilet) as shown

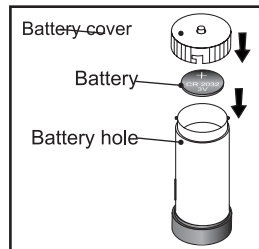

b.Open the battery cover and insert the battery into the battery hole. Note that the battery is printed with + CR 2032 3V (exclude) with the positive side of the battery facing up, as shown

5. Knob remote re-code matching

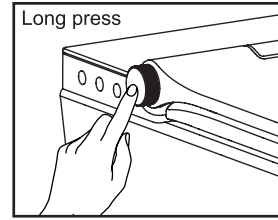
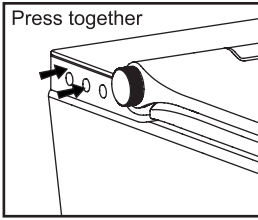

a. Press the “Power Supply and “Rear wash” button at the same time. When you release it, you hear a long beep from the host, and the host is in the code state (if there is no beep, it may be due to different pressing, you can try again).

b. Press and hold the “knob” until you hear a long beep from the host, which means that the code is successfully coded; about 10 seconds, the code is successfully coded. If it is unsuccessful, try again according to the above steps; if it is still unsuccessful, please consult the after-sales service.

3.2 Toilet button description

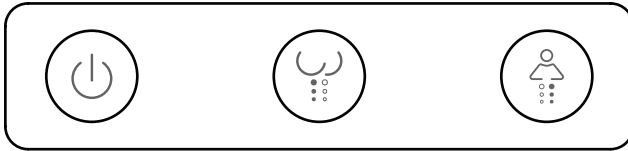

Power Supply

Rear Wash

Women Wash

The intelligent toilet is in use and the "Power Supply" is pressed to end the current operation.

When the intelligent toilet is not in use, press and hold for more than three seconds to turn off the

Press the “Rear wash” button, the Rear wash is activated, the nozzle is extended, gently and safely clean rear position.

Press the “Rear wash” button again or press the stop

Press the “Women wash” button, the Women wash is activated, the nozzle is extended, gently and safely clean the women position.

Press the “Women wash” button again or press the stop

intelligent toilet.

button on the remote control to end, or it will end automatically after 3 minute.

button on the remote control to end, or it will end automatically after 3 minute.

When the toilet is in any function mode, press any button again to stop the current working state.

3.3 Rotate knob operation instructions

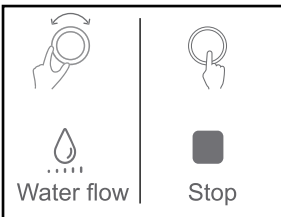
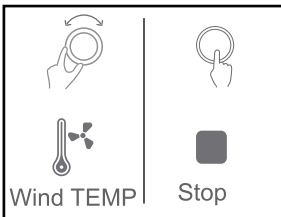
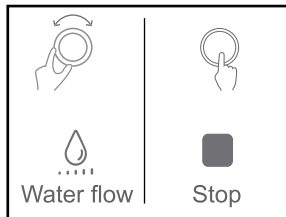

Under the condition of sitting induction, rotate backward to activate rear wash function.

1. Short beep when function is turned on, short beep when function is turned off; 3min period;
2. In the washing state, the forward spin volume becomes large, and 4 levels can be adjusted. Each adjustment is accompa-

Press the knob to activate the warm air drying function under the condition of sensor and non-flushing.

1. Short beep when function is turned on, short beep when function is turned off; 4mins period;
2. In the drying state, when spin forward the wind temperature increased, and 5 levels can be adjusted. Each ad-

Under the condition of induction, rotate forward to activate the women wash function.

1. Short beep when function is turned on, short beep when function is turned off; 3min period;
2. In the washing state, the forward spin volume becomes large, and 4 levels can be adjusted. Each adjust-

nied by a short beep and two beeps when the maximum position is reached;

3. In the washing state, the backspin flow becomes small, and 4 levels can be adjusted. Each adjustment is accompanied by a beep and two beeps when the minimum position is reached; Press knob to stop rear wash function.

justment is accompanied by a short beep and two beeps when the maximum position is reached.

3. In the drying state, when backspin the wind temperature is reduced, and 5 levels can be adjusted. Each adjustment is accompanied by a short beep and two beeps when the minimum is reached.

Press knob to stop the drying function

ment is accompanied by a short beep and two beeps when the maximum position is reached;

3. In the washing state, the backspin flow becomes small, and 4 levels can be adjusted. Each adjustment is accompanied by a beep and two beeps when the minimum position is reached;

Press knob to stop women wash function.

3.4 Remote button operation instructions

This intelligent toilet is operated by knob and remote control. Knob can control buttock to wash, woman to wash, dry and stop. Other functions are controlled by the remote control, including Settings that are also changed by the remote control. Press the corresponding button on the remote control to activate the corresponding function. The button will briefly light up in the white backlight and disappear after 5 seconds.

In any case, stop the button for the highest priority response; When more than 2 keys are detected, the first button is valid;

If the remote control is not available, please check whether the battery is installed or whether the battery is charged. If not, please refer to the initialization operation to install the battery.

Stop

Press the "Stop" button to stop the function operation in progress.

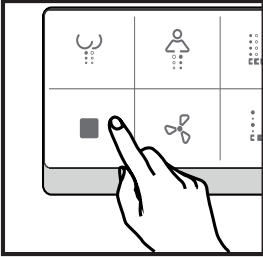

In any case, stop the button with the highest priority and press to end the current operation.

When more than 2 keys are detected to be pressed, the key pressed first is valid.



Rear Wash

Press the "Rear Wash" button, the indicator light will turn on, the system buzzer will beep, and the Rear wash function will start.

Conditions: in the seat induction conditions.

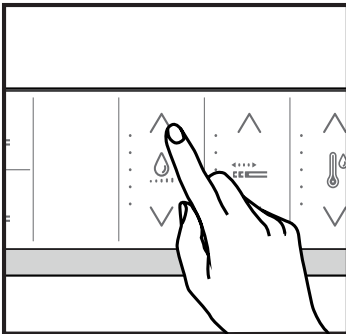

In the state of Rear washing, press " ^ " in "Water flow Adjustment" to increase the water spray intensity; press " v " to decrease the water spray intensity.

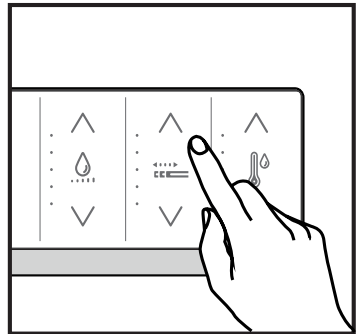

In the Rear washing state, press " ^ " in "Nozzle position adjustment" to move the nozzle forward; press " v " to move the nozzle backward.

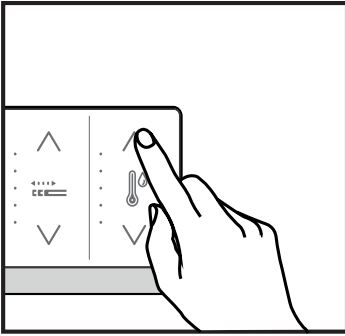

In the state of Rear washing, press " ^ " in "Water temperature adjustment" to increase the water temperature; press " v " to lower the water temperature.

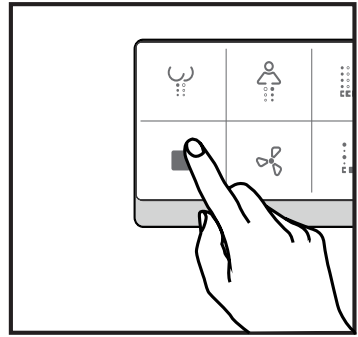

Press the "Stop" button to stop "Rear Wash" or wait for 3 minutes to stop automatically.



Women Wash

Press the "Women Wash" button, the indicator light will turn on, the system buzzer will beep, and the women's washing function will start.

Conditions: in the seat induction conditions.

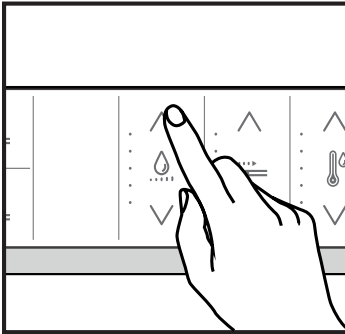

In the state of Women washing, press " ^ " in "Water flow Adjustment" to increase the water spray intensity; press " v " to decrease the water spray intensity.

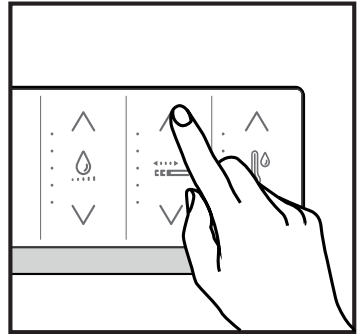

In the Women washing state, press " ^ " in "Nozzle position adjustment" to move the nozzle forward; press " v " to move the nozzle backward.

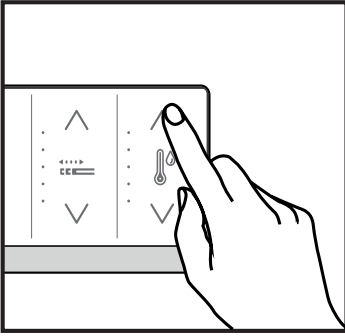

In the state of Women washing, press " ^ " in "Water temperature adjustment" to increase the water temperature; press " v " to lower the water temperature.

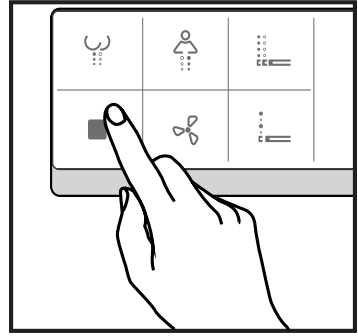

Press the "Stop" button to stop "Women Wash" or wait for 3 minutes to stop automatically.



Drying

Press the "Dry" button to blow out comfortable warm air. Room temperature $50 \pm 10 \text{ }^\circ\text{C}$ (Max)

Conditions: in the seat induction conditions.

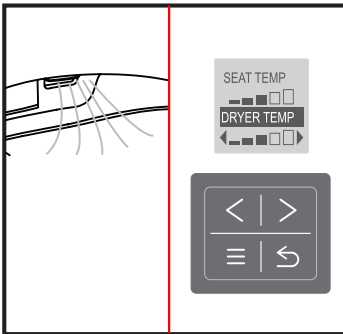

"Drying" is activated, the warm air cover is opened, and comfortable warm air is blown out.

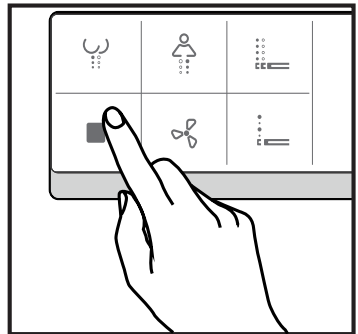

Press the "Stop" button to stop "Drying" or wait for 4 minutes to stop automatically.



Mobile message wash

"Mobile message wash", when using the cleaning function, the nozzle moves back and forth.

Condition: Rear wash or Women wash function have been activated.

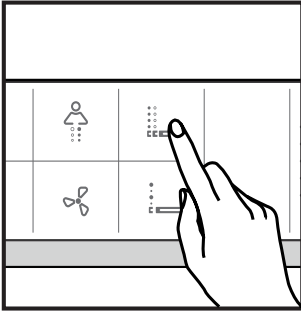

"Mobile message wash" is activated and the nozzle moves back and forth.

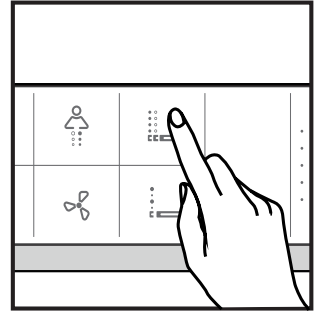

Press "Mobile message wash" again to stop "Mobile message wash" and switch back to Rear wash / women wash, or wait for 3 minutes to stop automatically.



Pulse message

"Pulse message" key, the water spray strength changes when using the cleaning function.

Condition: Rear wash or Woman wash function has been activate.

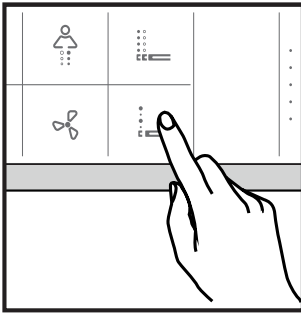

"Pulse massage" is activated and the intensity of the water spray changes.

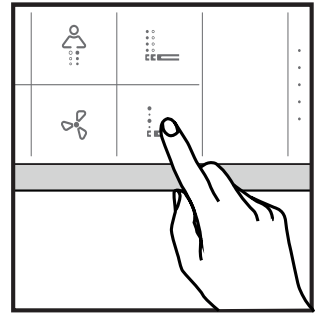

Press "Pulse Massage" again to stop "Pulse Massage" and switch back to Rear Wash / Women Wash, or wait for 3 minutes to stop automatically.



Nozzle position adjustment

There are 5 levels of nozzle position adjustment. The default setting is level 3.

Condition: Rear wash or Woman wash function has been activate.

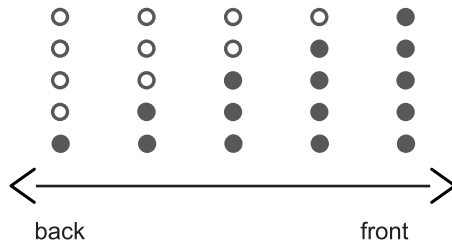

Press the “^” key in the nozzle position, the nozzle extends forward, and each time you press it, it increases by 1 level until it is at the higher level. When you press the “v” key, the nozzle is retracted backward, and each time you press it, it decreases by 1 level to the lower position.



Water flow adjustment

There are 5 levels of water flow adjustment. The default setting is level 3.

Condition: Rear wash or Woman wash function has been activate.

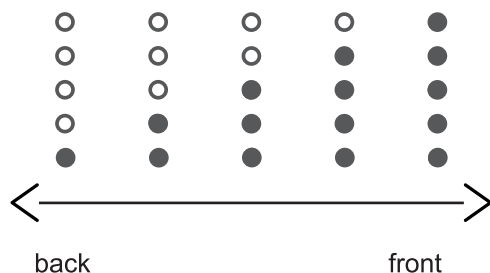

Press the “^” key to increase the water flow. Each time you press it, it increases by 1 level until it reaches the highest level. Press the “v” key to decrease the water flow. Each time you press it, it decreases by 1 level till it reaches the lowest level.



Water temperature adjustment

There are 5 levels of water temperature adjustment (off ,

30, 32, 34, 36, 38°C). The default setting is level 3.

Condition: Rear wash or Woman wash function has been activate.

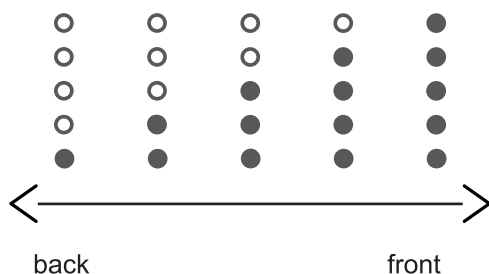

Press the “^” key to increase the water temperature. Each time you press it, it increase by 1 level until it reaches to highest level. Press the “v” to decrease the water temperature. Each time you press it, it decrease by 1 level till it reaches to lowest level.



Seat temperature adjustment

There are 5 levels of Seat temperature adjustment

(off , 30, 32, 34, 36, 38 °C). The default setting is level 3.

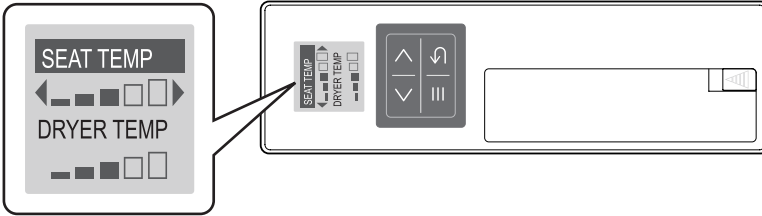

Press the “ > ” key to increase the Seat heating temperature. Each time you press it, it increase by 1 level until it reaches to highest level. Press the “ < ” to decrease the heating temperature. Each time you press it, it decrease by 1 level till it reaches to lowest level (Off).

3.5 Descaling reminder setting (the remote's back)

Due to the difference in the hardness of the water, scale will form over a long period of time. After the all-in-one is installed, you need to use the "total hardness test strip" (included in the package) to test the local water quality.

The test method is as follows:

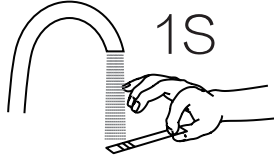

ppm(gpg) (Please refer to the actual color card color)

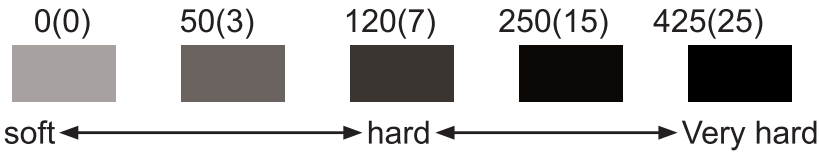

Measure the water quality at the installation site, immerse the reaction zone in the test solution for 1 second, and remove excess water drops;

After leaving it for 15 seconds, compare the color of the test result with the table in the figure above (please refer to the actual color of the color card). The color is close to the concentration value.

Set the descaling reminder conditions on the back of the remote control according to the value.

If the reading is between two gears, select the higher gear.

Setting method (example: when the concentration value is 120ppm, descaling reminder once):

MENU 2/4	AUTO FUNCTION 3/3	DESCALING REMINDER 1/4	WATER HARDNESS 120ppm
1. CLEAN & PRE-WET	2. NIGHT LIGHT	1. 120ppm	
2. AUTO FUNCTION	3. DESCALING REMINDER	2. 250ppm	
▼	▼	▼	

When the set descaling period is up, the descaling reminder light flashes, please add descaling liquid to descale the product.

Chapter 4 Cleaning and Maintenance.

4.1 Toilet seat unit cleaning

Clean the seat unit regularly, or immediately after being stained with dirt. If not cleaned regularly, the dirt may become noticeable, and become stubborn.

Be sure to cut off the power supply before cleaning the surface of the product. Do not put water or detergent into the product or the power plug, which may cause short circuit, electric shock, or fire.

Attention: discoloration, yellowing or peeling of paint due to improper cleaning.

- Do not use corrosive cleaners or cleaners containing chlorine or acids.
- Use only cleaning agents and equipment specific to this application.
- Follow the detergent instructions.
- Never mix detergents.

Wipe with a soft damp cloth. A neutral soap solution is an ideal daily cleaner.

4.2 Nozzle cleaning

The nozzle will retract automatically for self-cleaning before and after cleaning function.

● Manually clean the nozzle.

Clean the nozzles regularly or immediately after dirt is found.

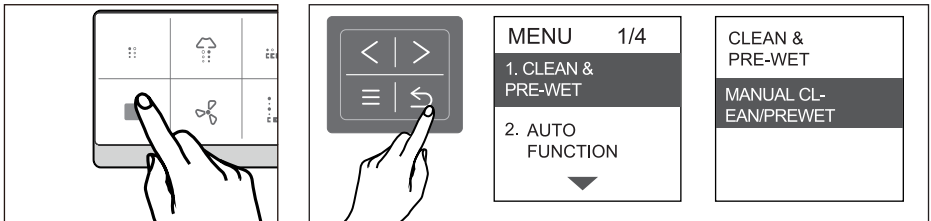

1. Press the stop button to ensure the toilet is standby.

2. Select the CLEAN & PRE-WET and confirm MANUAL CLEAN/PREWET, the nozzle extends without water.

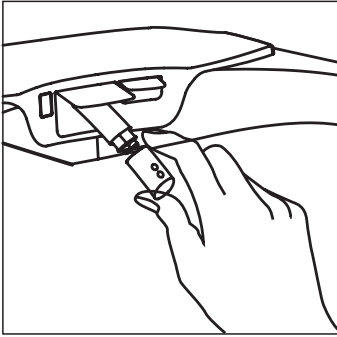

3.Remove the spray head, and clean the spray head with a cloth, sponge or brush and neutral detergent.

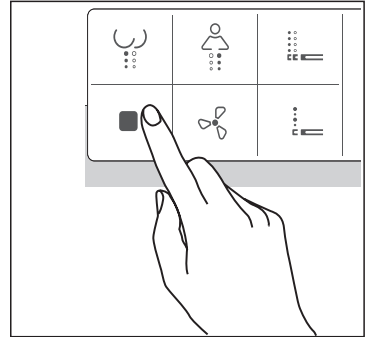

4. Put back the cleaned spray head, click "Stop" on the front of the remote control again to end, and the nozzle will retract.

4.3 Pre-wet on and off

The Original Setup for pre-wet is "ON". If you would like to turn off the pre-wet function, please follow the below instruction:

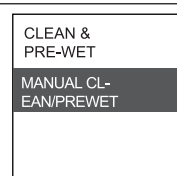
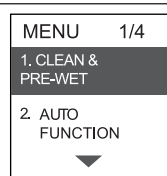
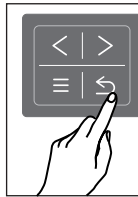
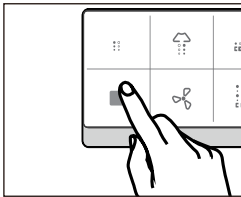

1.Press the stop button to ensure the toilet is standby.

2.Select the CLEAN & PRE-WET and confirm MANUAL CLEAN/PREWET, the nozzle extends without water.

3.Press the stop button, the nozzle withdraws back. The pre-wet function turns off.

4.Repeat the above steps if you would like to turn on the pre-wet function. (The operation is the same as nozzle and sprayer clean.)

4.4 Remote control cleaning

Clean the remote control and remote control bracket with a soft, damp cloth.

4.5 Deodorizing device cleaning

1. When there is too much dust on the deodorization box, the amount of inhaled air will decrease. Please use a toothbrush or a small brush to remove the dust. The specific steps as follow:

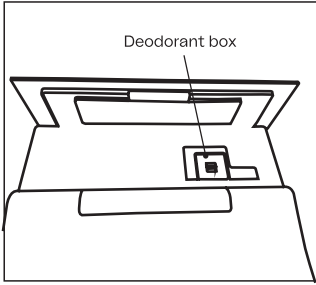

① Open the glass cover on the rear of the product.

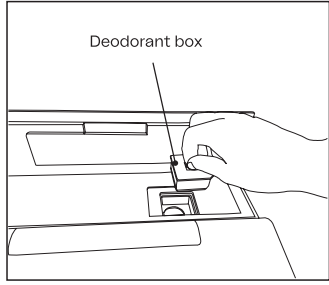

② Remove the deodorant box.

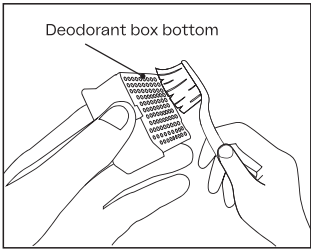

③ Use a toothbrush or a brush to clean the bottom of the deodorant box until there is no dust or paper dust.

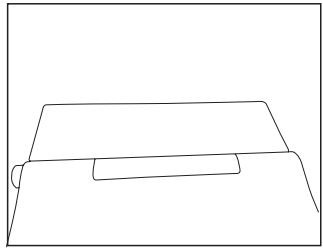

④ Put the cleaned deodorant box back into the groove, and cover the glass cover again.

Do not wash the deodorant box with water, otherwise the deodorizing effect will be lost.

Placing the deodorant box in the sun for several hours can extend the life of the deodorant.

2. After cleaning the deodorant box and the deodorizing suction port, if there is still odor generated, Please replace the deodorant.

The specific operations as follow:

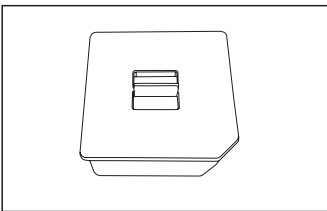

① Remove the deodorant box from the back of the product.

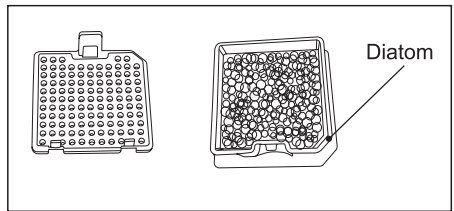

② Open the deodorant box.

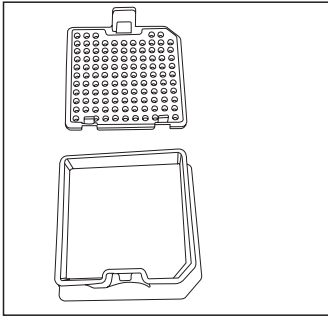

③ Remove the old diatom from the box.

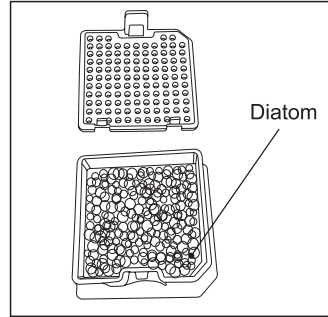

④ .Replace with new diatom.

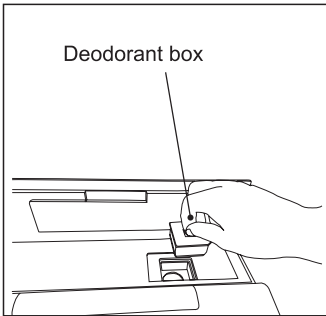

⑤ Put the new box back into the groove of the product.

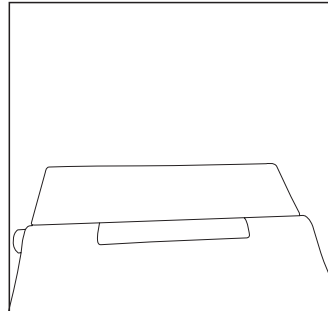

⑥ Close the glass cover.

4.6 Descaling

Due to the different degrees of softness and hardness of water, scale will form during long-term accumulation, once every three months, descaling steps are as follows:

Descaling Tip: The descaling prompt light on the glass panel flashes.

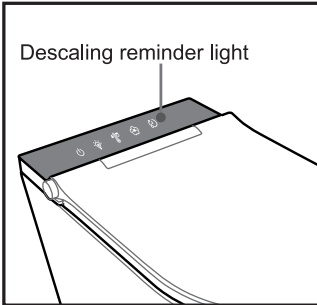

1. Open the rear glass cover.

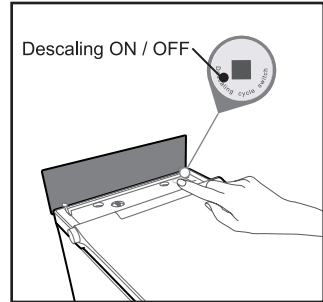

2. Press the descaling key and start the water tank to drain; the nozzle will self-clean the water during the drainage process, accompanied by drops ... beep. If misoperation, the host can be used normally after power off and restart.

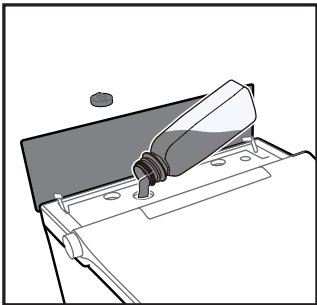

3. After the water tank is drained, the beeping stops; add the descaling solution (recommended coffee machine descaling solution); add the maximum descaling solution capacity: $V_{max} \leq 250\text{ml}$.

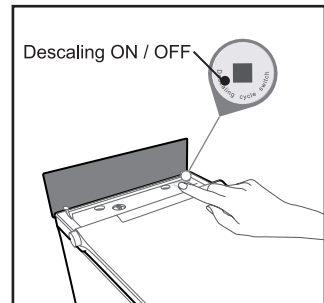

4. Press the descaling key again to start the descaling cycle.

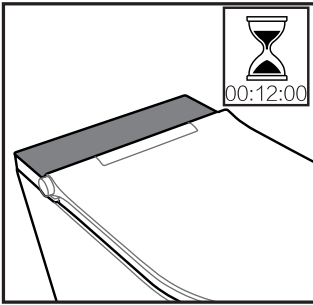

5. During the descaling process, the status lamp flashes. After 12 minutes, the descaling is completed and the status lamp is displayed normally.

Note: The descaling liquid needs to be purchased by the user. It is recommended to purchase a descaling liquid for the coffee machine (it can only be used to clean the limescale, not for other purposes, and not allowed for children to play).

4.7 Waste disposal

Electrical and electronic equipment may contain hazardous or hazardous substances. Do not discard it as unsorted household waste. Please send it to the designated collection point. In this way, you can contribute to resource conservation and environmental protection. Contact your retailer or local authorities for more information.

Used batteries must be disposed of properly. To this end, battery recycling bins with corresponding labels are available in stores and community collection stations where batteries are sold.

To avoid possible suffocation or danger, do not let children play with plastic bags and product packaging. Please keep such packaging materials in a safe place or discard them in an environmentally friendly manner. If possible, keep the packing materials until the end of the warranty period.

4.8 Product maintenance

In the following cases, please close the water inlet valve and remove the hose to drain the water.

- When water may freeze in cold areas.
- When not used for a long time.

It may cause skin infection due to deterioration of residual water.

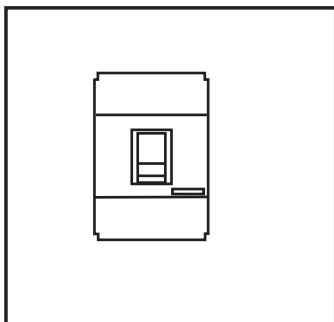

1. Turn off the power of this toilet.

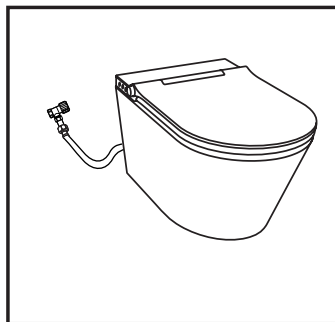

2. Close the valve and stop supplying water to the system.

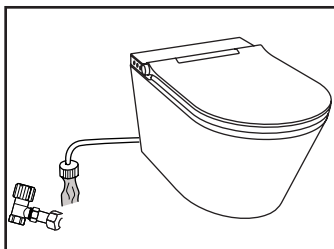

3. Remove the water inlet hose from the water inlet valve and drain the water from the tube.

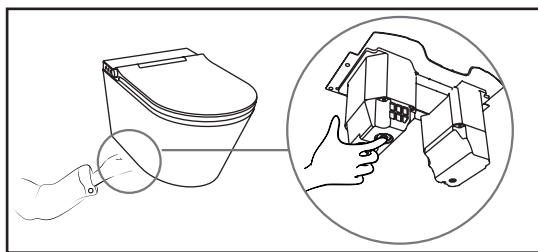

4. Water quality conditions are different in different regions. Please clean the water tank regularly. Blocking of dirt may cause the water flow to decrease. (Recommended once every 2-6 months). Drain the water

in the water tank by pressing the drain button under the water tank. (As shown in FIG).

4.9 Winter Product Maintenance

When freezing may occur in winter, etc., in order to prevent damage to the hose or product due to freezing, please take measures to prevent freezing:

- a. Increase the room temperature;
- b. Close the water inlet angle valve and drain the water from the water inlet hose.

Chapter 5 Fault predication and Troubleshooting

Recommendation: Initial basic operation in case of failure

Turn off the main power of the product, and then turn it on again after at least 3 minutes.

If your device still does not work properly after following the instructions described below, please contact your company's customer service center or your dealer.

Condition	Possible reason	Solution
Basic function		
Function does not work at all	Power failure	Please wait for power to be restored
	Plug loose or out of touch	Please plug in to ensure the power is restored
	The leakage protection button of the power cord is not on	Please press the leakage switch of the power cord
	In standby mode	Switch to on mode
water leakage	Malfunction	Close the water supply Disconnect the power Call Customer Service Hotline
Remote control		
During operation, the indicator light of remote control keeps flashing	Battery power is low	Replacement battery

Condition	Possible reason	Solution
The remote does not work	No battery inserted	Load the battery
	Run out of power	Replacement battery
	Battery is positive and negative	Load the battery correctly
	Defective remote control	Call Customer Service Hotline

 Warning	<p>Do not disassemble, repair or modify the product yourself. It may cause electric shock, fire or malfunction.</p>
--	---

Condition	Possible reason	Solution
Rear Wash / Women Wash		
It takes slightly long to switch between Rear wash and Woman wash	When switching between Rear wash and Women wash, the spray head needs to be retracted and self-cleaning before extending.	Normal
Cleaning nozzle does not extend	Water inlet hose bend	Exclude water hose bent Call Customer Service Hotline
The cleaning water does not spray out	Water supply was cut off	Please wait for water to be restored
	Inlet angle valve is not open or is blocked by dirt	Open or clean the inlet angle valve
	Water inlet hose bend	Exclude bent water hose Call Customer Service Hotline
	Nozzle blocked	Cleaning nozzle

Condition	Possible reason	Solution
Abnormal water spray	Abnormal operation malfunction	Power on again after unplugging for one minute Call Customer Service Hotline
Water spray intensity is too weak	Water spray intensity has been set to "1st"	Adjust the water spray intensity to 2nd, 3rd, 4th or 5th
	Nozzle blocked	Cleaning spout
	Inlet water filter blocked	Cleaning the decompression valve filter
	Deformed of water inlet hose	Call Customer Service Hotline
The water temperature is not high enough	Water temperature has been set to "Off" or "1st gear"	Set the water temperature to 2nd, 3rd, 4th or 5th
Water temperature is too high	Water temperature has been set to "5th gear"	Set the water temperature to 1st, 2nd, 3rd or 4th
Nozzle suddenly stopped spraying water	The function stops automatically after 3 minutes	Normal
Retracted nozzle drips water	The nozzle is automatically cleaned before and after the cleaning function	Normal
Drying		
No reaction	The human body is not within the sensing range	Adjust sitting position, posture, etc.
Warm air temperature is too low	The drying temperature has been set to "1st gear"	Set the drying temperature to 2nd, 3rd, 4th or 5th
Warm air temperature is too high	The drying temperature has been set to "5th gear"	Set the drying temperature to 1st, 2nd, 3rd or 4th

Condition	Possible reason	Solution
Deodorizing		
Deodorizing effect is not good	Dust clogging	Cleaning deodorant box
Deodorization produces loud noise	Dust clogging	Clean the deodorizing suction port

In the following cases, be sure to contact the service point.

After reinserting the power plug, the indicator light on the toilet body is still blinking. (Please unplug)

After reinserting the power, the indicator light on the toilet body is still off.

When smoking or abnormal sound occurs. (Please unplug the power plug)

Chapter 6 Technical date

Model		STO-G7/STO-G9
Rated Power		1250W
Water supply connector		G1/2XG1/2
Applicable voltage		AC 220V~240V, 50/60Hz
Length of wire		1.8m
Applicable range of water pressure		0.07 ~ 0.75MPa(0.7 ~ 7.5Bar)
Suitable intake temperature		4 ~ 30°C
Applicable ambient temperature		4 ~ 40°C
Waterproof grade		IPX4
Washing device	Flow rate	550 ~ 750ml/min
	Water temperature	Off, 30 ~ 38 °C
	Cycle	3min
	Warm water heating method	Instant heater heating
	Maximum heating power	1400W
	Safety device	Temperature fuse, level switch, thermostat
	Backflow preventer	Air gap
Drying device	Min wind volume	0.2m ³ /min
	Maximum heating power	230W
	Drying cycle	4min
	Warm wind temperature	Off, 30 ~ 60°C
	Safety device	Emperature Controller, Temperature Fuse
Seat heating	The surface temperature	Off, 30 ~ 38 °C
	Heating power	50W
	Safety device	Thermostat, temperature fuse
Deodorization method		Diatom pure
Net weight		35.6 Kg
Size		660*435*520 mm

The final interpretation right of this manual belongs to the company.
Products are subject to change without notice.

First copy: saved by the customer

Service card			
Product model			
Serial number		Purchase date	
Dealer		Telephone	
City		Province	
Country		Dealer's stamp	
Maintenance regulations:			
<p>1. In accordance with the instructions and precautions for use, if a failure occurs after normal use, repair will be performed free of charge during the warranty period.</p> <p>2. Please contact the company's customer service center or the seller for repairs due to failures during the warranty period, and show the repair service card during repairs.</p> <p>3. Although it is under warranty, the following conditions will be charged for maintenance.</p> <ul style="list-style-type: none">-Failures due to carelessness or negligence during use, and failures due to improper repair or modification.-Failure or damage to the mobile installation location.-Faults and damage caused by fire, earthquake, flood, lightning, and other natural disasters, pollution, or abnormal voltage.-Failures and damage caused by the use of unspecified power sources (voltage, frequency).-Used for purposes other than general domestic use, malfunctions or damage.-Cases where this repair card cannot be provided.-When the unit sold, the installation date, the seal of the dealer, etc. are not filled in this repair card or the contents are modified without authorization. <p>4. This repair card is no longer issued, please keep it properly.</p>			

Second copy: sent back to company headquarters

.....
Crop line

Service card	
Product number	
Serial number	
Customer name	
Contact number	
Detailed address	
Units Sold	
Contact number	
Purchase date	

Maintenance records			
Maintenance date	Maintenance project	Maintenance unit	Signature of maintenance staff

ARUVO[®]